

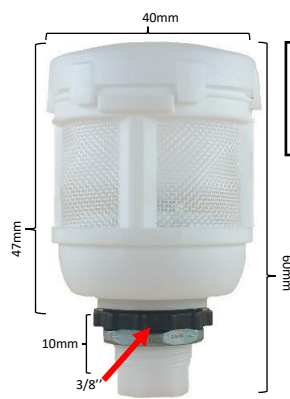

TYPE I
Référence : 4DEPFS6051300
Pour marque DELTECH

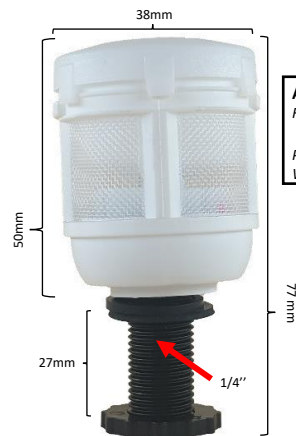

TYPE II
Référence : 4DEPFS6051400
Pour marque COMPAIR /
NORGREN / MIKROPOR



ADV 3000
Référence : 4WRFIS00140
Pour marque AFE /
WALKER / WILKERSON

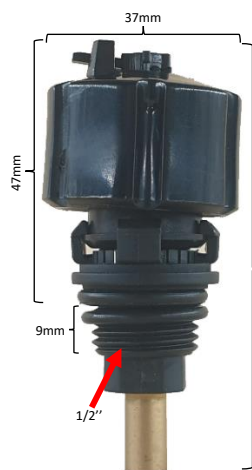

G 20
Référence : 4PNGADPURG20
Pour marque ZANDER / OMI /
KAESER / BEKO / HANKISON /
DONALDSON DF

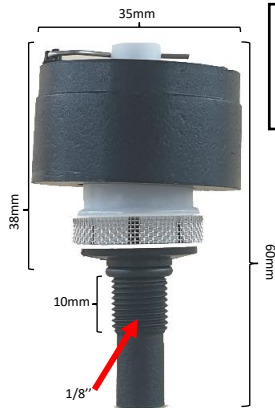

WAD
Référence : 4DEPFS061095
Pour marque WATTS /
ULTRAFILTER 80 /
COMPAIR 80

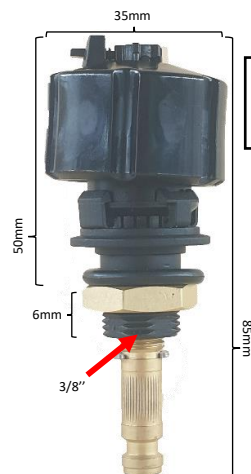

G 17
Référence : 4PNGADPURG17
Pour marque ATLAS COPCO

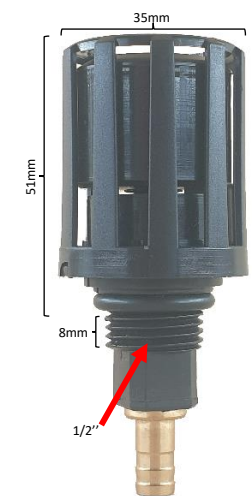

PSL 15
Référence : 4OAFIS000016
Pour marque ABAC /
ATLAS COPCO /
CREYSSENSAC

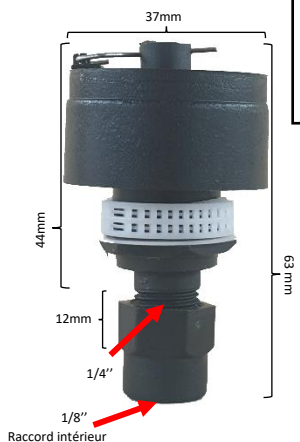

GN 12
Référence : 4PNGADPURGN12
Pour marque ZANDER /
KASER / HANKISON /
CHAMPION / OMI

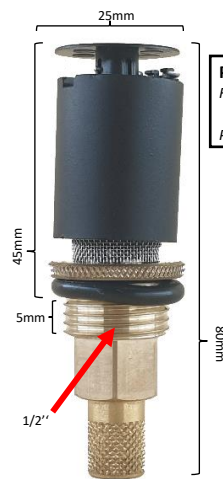

PXPA
Référence : 4KSPXSP00110
Pour marque PHENIX

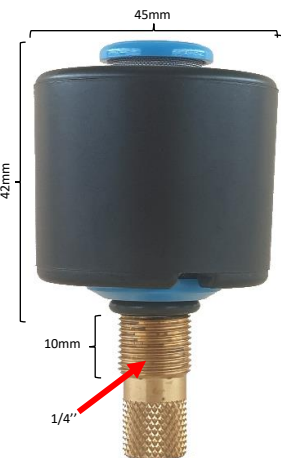

NGF 02-12
Référence : 4DEPFS129025
Pour marque DELTECH

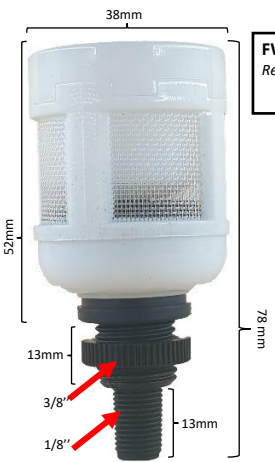

FW 16
Référence : 4PNGADPURFW16

Pour toutes demandes : info@partenaire.fr
Pour toutes commandes : commandes@partenaire.fr
Téléphone : +33 (0)1 34 60 00 00
Retrouvez-nous sur notre site : www.partenaire.fr

Z.A. Charles RENARD, 12 Bd G. M. GUYNEMER
78210 SAINT-CYR-L'ÉCOLE





TYPE A
Référence : 4AFIADPA00516

Dimensions: 35mm (top), 37mm (middle), 16mm (thread), 75mm (total), 3/8" (thread), 20mm (small part), 1/8" (small part).



TYPE B
Référence : 4AFIADPB00516

Dimensions: 35mm (top), 37mm (middle), 16mm (thread), 75mm (total), 3/8" (thread).



TYPE C
Référence : 4AFIADPC00516

Dimensions: 35mm (top), 37mm (middle), 15mm (thread), 75mm (total), 1/2" (thread).



TYPE D
Référence : 4AFIADPD00516

Dimensions: 35mm (top), 37mm (middle), 16mm (thread), 76mm (total), 1/8" (thread).

NOUVEAUTE

Gamme en acier inoxydable

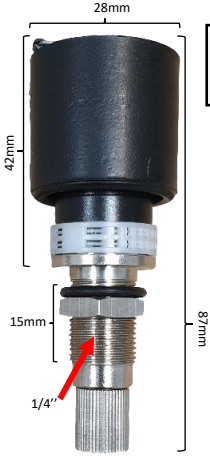

GNS 14
Référence : 4PNGADPURGNS14

Dimensions: 28mm (top), 42mm (middle), 15mm (thread), 87mm (total), 1/4" (thread).

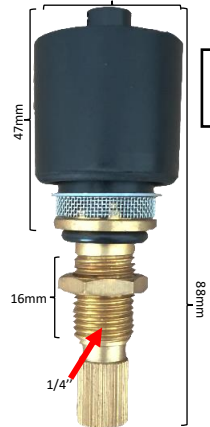

GNS 13
Référence : 4PNGADPURGNS13

Dimensions: 28mm (top), 47mm (middle), 16mm (thread), 89mm (total), 1/4" (thread).

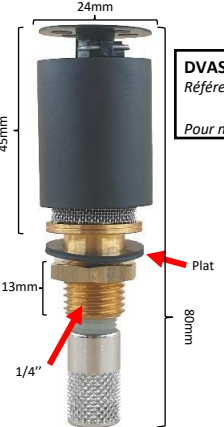

DVAS 16 C
Référence : 4WRFISP00110
Pour marque WALKER

Dimensions: 24mm (top), 45mm (middle), 13mm (thread), 80mm (total), 1/4" (thread). Plat (arrow).

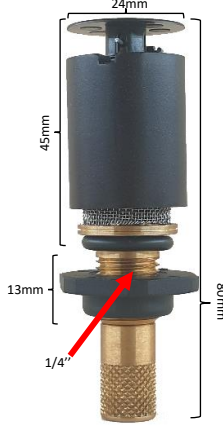

DVAS 16
Référence : 4WRFISP00120
Pour marque WALKER

Dimensions: 24mm (top), 45mm (middle), 13mm (thread), 80mm (total), 1/4" (thread).

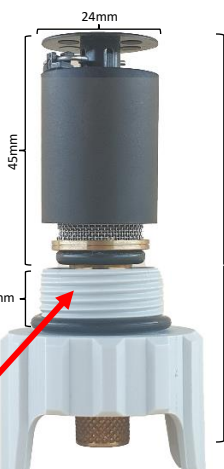

ADVSE 16 montage ext.
Référence : 4WRFISP00160
Pour marque WALKER

Dimensions: 24mm (top), 45mm (middle), 10mm (thread), 80mm (total), 3/4" (thread).

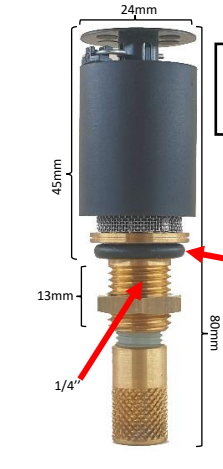

ADV 16
Référence : 4WRFISP00130
Pour marque WALKER

Dimensions: 24mm (top), 45mm (middle), 13mm (thread), 80mm (total), 1/4" (thread). Torique (arrow).



AD 202 PURGEUR EXT.
Référence : 4PNGADPURAD202

Dimensions: 45mm (top), 12mm (thread), 140mm (total), 1/2" (thread).

Pour toutes demandes : info@partenair.fr
 Pour toutes commandes : commandes@partenair.fr
 Téléphone : +33 (0)1 34 60 00 00
 Retrouvez-nous sur notre site : www.partenair.fr
 Z.A. Charles RENARD, 12 Bd G. M. GUYNEMER
 78210 SAINT-CYR-L'ÉCOLE

